

Three Phase

Kolb Atollspeed 400T GC-3072

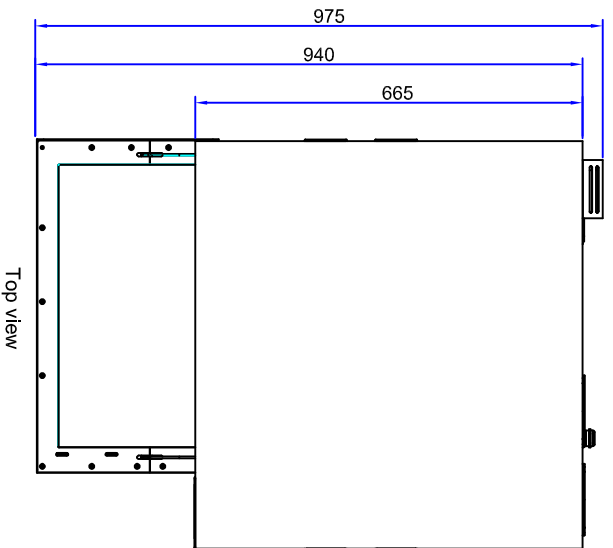
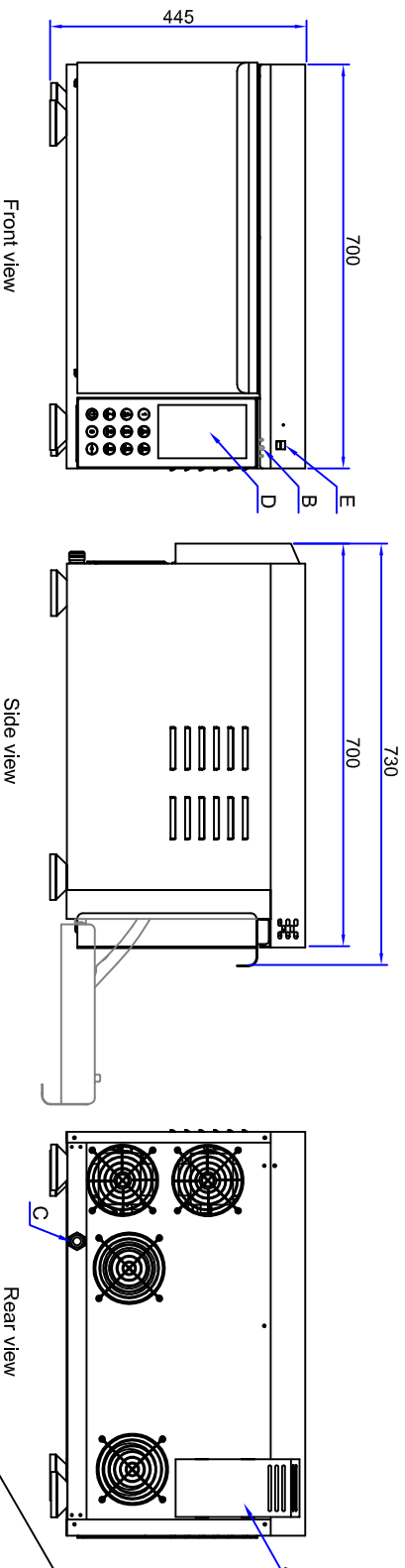

- A Steam discharge cover
- B Temperature limiter cover
- C Power cable
- D Touch screen display
- E USB

Dimension:
 Door open dimension: 700(W) x 730(D) x 445(H) mm
 Baking chamber dimension: 700(W) x 975(D) x 445(H) mm
 Standard Voltage: 450(V) x 350(D) x 200(H) mm
 Standard Voltage: 380-400V / 3ph / 50 Hz
 Optional Voltage: 415 V (Specify on order)
 Optional Frequency: 60 Hz (Specify on order)
 Power: 4.9 kW
 Microwave input power: 3.2 kW
 Heating power: 3.3 kW
 Current: 16 A
 Weight: 94 kg
 Microwave frequency: 2.465 GHz
 Circuit breaker: 3 x D20
 Wiring: 2.5 mm²

Signature: _____
 Date: _____

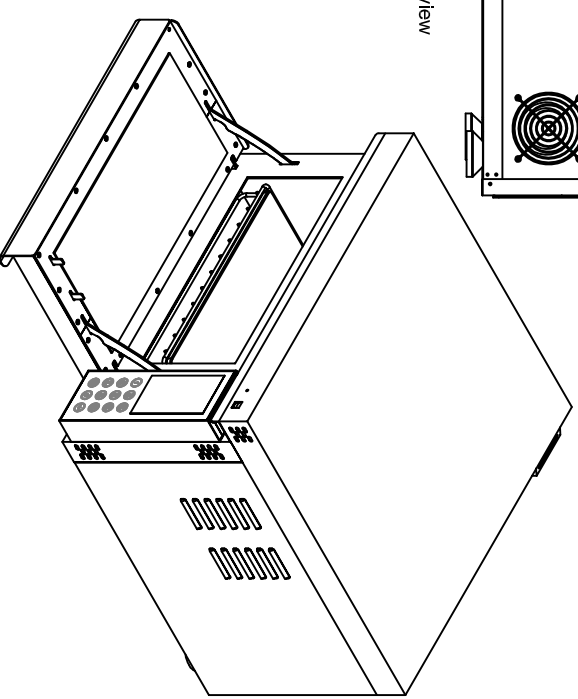

Unassigned Tolerance According to DIN ISO 2768-1									
Dimension	0.3 To 6	6 To 30	30 To 120	120 To 400	Radius 0.5 To 3	Radius 3 To 6			
Tolerance	±0.1	±0.2	±0.3	±0.5	±0.2	±0.5			
									mm

Kolb Huizhou Ltd.

Tolerance		Customer Title: Atollspeed 400T	Material: SS304
X.±	X.°	Kolb Item Number:	Version: 01
.X±	.X°	Kolb Item Name: Atollspeed 400T	
.XX±	.XX°	Weight	Thickness
		Item Number	Page

Quantity	1	Approve	Check	Draft	Min	Unit	Scale
		Date	Date	Date	03.12.2013	mm	1:1

Weight	Thickness	Item Number	Page
		GC-3072	1/1